

GASER

TURN TABLE 1200-1500-2000

MOTORIZED ROTARY TABLES

MACHINERY FOR THE
FOOD INDUSTRY

Rotary table to facilitate collection after exiting the breading machine or the frying line.

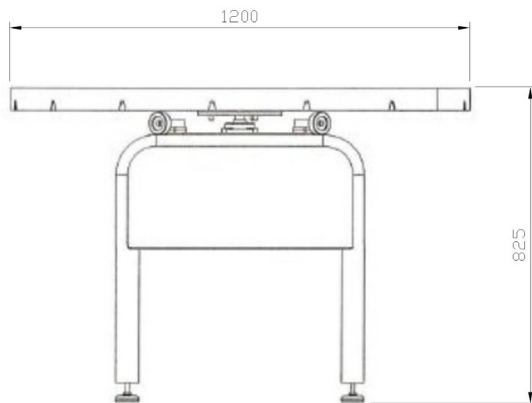

- Made of stainless steel.
- Upper working zone made of polythene for food products or stainless steel.
- Diameter at choice 1.200 mm, 1.500 mm or 2.000 mm.
- Adjustable height: 850 mm.
- Speed rotation: 10 rpm.
- Power: 0,12 kW.
- Rotary turntable 1.200 mm with polythene upper working zone.
- Rotary turntable 1.500 mm with stainless steel upper working zone.
- Rotary turntable 2.000 mm with stainless steel upper working zone.